

Microscopy and Imaging Center Facility Manual

October 2020

Contents

1. Gaining Access to the MIC.....	2
1.1 Becoming a new user.....	2
1.2 Training request on an instrument.....	2
1.3 Card access to the facility.....	2
1.4 Location and Parking.....	3
2. Billing.....	3
2.1 Billing protocol.....	3
2.1 Equipment reservation policies.....	4
2.2 iLab kiosk.....	5
2.3 Equipment failure.....	6
3. Data policies.....	7
4. Safety.....	7
4.1 General Safety Information.....	7
4.2 Biohazardous safety.....	8
5. Samples.....	10
5.1 Sample processing.....	10
5.2 Experiment error.....	11
6. MIC Facility Seed Grant Program.....	12
7. Export Controls.....	14
8. Confidentiality.....	14
9. MIC Acknowledgement Policy.....	14
10. MIC floor map.....	16

1. Gaining Access to the MIC

1.1 Becoming a new user

To become an MIC user, you will need to contact the scientist in charge of that instrument via email listed on the website.

You will then need to set up an iLab account and fill out a Training Request Form. At the end of the form, you will acknowledge that you have read and understood this MIC Lab Manual.

You will again contact the appropriate staff member of the MIC to say that you have completed your Training Request Form and set up a time to meet and begin training.

1.2 Training request on an instrument

If you are already an iLab user and would like to request training on a new instrument you will need to contact the appropriate staff member and fill out a Training Request Form for the instrument.

1.3 Card access to the facility

Once training is complete and a user is “checked out”, that user will be given student ID card swipe access to the MIC facility after-hours as well as the appropriate lab room where the instrument is housed. After-hours and weekend operation of equipment is available at an “off-peak rate” for qualified users who have been trained to operate instruments independently.

1.4 Location and Parking

The MIC is located in the ILSB building next to the Albritton clock tower on Wellborn Road. Driving instructions to the facility from University Drive can be found [here](#). Visitors to the Center can park in one of the four designated MIC reserved spaces in Lot 42 adjacent to the west side of ILSB. When parking in one of these spaces, you must register your vehicle in the MIC's administrative office (outside Room #1137) upon arrival. These spaces are first come, first serve. In the event all visitor parking spaces are occupied, additional parking can be found in the Central Campus Parking Garage (CCPG). To find the [location of the garage on a campus map, click here](#).

2. Billing

2.1 Billing Protocol

Users of the facility will be billed each month for their usage through iLab. When receiving training you will be billed for the appropriate instrument time as well as staff time. If you would like to request refresher training, consultation, or other staff assistance please note that you will be charged for staff time. External customers will be charged an external rate for instrument usage and staff time. Other university researchers outside of the TAMU system will be charged a lower rate and internal TAMU customers will be charged an even more subsidized rate. After-hours (5pm to 8am) and weekend

operation of equipment is available at an “off-peak rate” for qualified users who have been trained to operate instruments independently.

2.2 Equipment Reservation Policies

Instruments can be scheduled up to 2 weeks in advance and microscopes can be reserved for blocks up to 6 hours at a time no more than twice a day. Extended use may be allowed but must be approved by the appropriate staff equipment manager.

During training, a user will only be allowed to reserve equipment during MIC business hours from 8:00am-5:00pm on weekdays, excluding holidays.

Any reservation cancellations should be made 12 hours in advance to allow other users to schedule time on the instrument.

The assessment of a No Show fee will be at the discretion of the equipment manager. Users who do not show up (No Show) for their scheduled reservation could be charged as follows:

- First-time warning
- Second time-charged for the reserved time or for one hour, whichever is less.
- Third time-charged for the entire reservation

If a user or advisor feels that fees have been applied in error as a result of a medical or family emergency, the advisor should submit a written appeal to the equipment manager and the MIC Assistant Director.

2.3 iLab Kiosk

Upon arrival at the MIC to use the reserved instrument, users must check in at the kiosk located in the hallway. This will start the iLab session and turn on the interlock channels at the instrument. If more time is needed than what was reserved the user is responsible for extending their session in iLab. After equipment use is complete, users will log back into iLab at the kiosk and terminate their session. If this does not occur the user will be charged the walkout time.

Users who attempt to bypass interlocks will be held responsible and be restricted from using the MIC facility.

Any remote use of the MIC equipment must have an active iLab session and cannot be used to bypass usage fees.

2.4 Equipment Failure

No fee will be assessed for late cancellations or no-shows during any period when the instrument is unavailable because of maintenance or repairs.

If any problems with the equipment occur during operation or are discovered at check-in, the user is responsible for notifying the equipment manager as soon as possible.

PIs will be responsible for the cost of repairs from damages due to negligence or misuse of instruments by users in their group.

Proper usage and maintenance of the equipment are critical for optimal data collection. It is important that users properly perform the startup, shutdown, operating, and cleaning procedures as described in the training sessions. Users are responsible for returning equipment and/or accessories to their proper place at the end of each session. Failure to comply with all usage procedures as laid out in equipment tutorials, manuals, and training sessions can result in restricted or suspended access to MIC equipment. Users should contact the equipment manager with any questions or clarifications on procedures.

3. Data Policies

Users are responsible for their own data. Data and images collected on the local hard drive should be transferred from the microscope computers to portable media promptly. Users should bring a USB drive to take their data with them at the end of the session. Upon approval by the equipment manager, data may be stored up to 2 weeks and after that may be deleted without notice to the user/PI.

Do not, under any circumstances, download/upload programs or files onto MIC computers. Users doing so will have their use of the facility restricted. MIC computers are not to be used for any purpose other than MIC related activities.

4. Safety

4.1 General Safety Information

All users of the MIC are responsible for the safe utilization of instrumentation. Electrical and chemical hazards, as well as hazards associated with the utilization of high-vacuum instruments exist.

All new users of the facility shall receive site-specific safety training at the beginning of their instrument training.

No biohazardous material may be brought into the laboratory unless procedures for their use and disposal has been approved and all members of the MIC are properly informed of potential hazards.

A handbook of safety procedures and a Texas A&M University Hazardous Waste Disposal Manual is located at the entrance of the laboratory. Users of the laboratory are obligated to use proper safety procedures, and are expected to both read and understand the contents of these documents.

Material Data Safety Sheets are maintained on all chemicals used in the laboratory. Contact a staff member for manuals.

4.2 Biohazardous Safety

No Biosafety Level (BSL)-3, BSL-4 agents/pathogens or radioactive material are allowed in the facility at any time. BSL-2 agents/pathogens are only allowed in BSL-2 designated rooms with approval.

Selected rooms in the MIC have been approved as a BSL-2 laboratory space. In order to be able to bring any BSL-2 material to the MIC, the MIC facility and the room number MUST be listed in the investigator's approved TAMU Institutional Biosafety Committee (IBC) permit, in Section F, Agent use and Storage locations.

BSL-1 samples are only allowed in BSL-1 or BSL-2 designated rooms.

The investigator is required to send a copy of the approved IBC permit listing the relevant MIC laboratory rooms and the BSL-2 organisms along with copies of the required training certificates, to either Dr. Avery McIntosh (almcintosh@tamu.edu) or Dr. Stanislav Vitha (stanvitha@tamu.edu), before any BSL-2 samples can be brought into the MIC facility.

Reservations will not be approved until the information has been examined.

When using the BSL-2 labs in the MIC, all users must follow the rules posted. This applies even to those users that do not work with samples requiring an IBC permit.

Each user must fill out a 'use form' to demonstrate compliance with the Office of Environmental Health and Safety requirements regarding BSL-2 laboratory training and documentation of hazardous materials.

All BSL-2 materials must be transported to and from BSL-2 designated rooms using secondary containment that is clearly marked as biohazard.

Anything brought into the laboratory must be taken out for disposal following the conclusion of the experiment. All trash/waste within these rooms must be disposed properly.

For more information, please see the website for Research Compliance and Biosafety.

5. Samples

5.1 Sample processing

Sample processing is ONLY by appointment. Please contact the MIC staff before bringing samples to the lab. The MIC staff does its best to produce usable data from every experiment. However, this cannot be guaranteed, especially for pilot experiments. Each project involves consumables and staff time as well as instrument use. Investigators are given a cost estimate upon request, are informed of potential problems prior to the start of the experiment, and are expected to pay for all services requested and completed, even if data produced is not as anticipated by the investigator.

5.2 Experiment Error

There will be no charge for experiments that fail due to errors* by the MIC staff or equipment malfunction as long as no usable data is collected. If the investigator elects to collect data from experiments that are not up to standard, then normal charges will apply. The investigator may elect to terminate the project prior to completion. However, charges will be applied for all procedures completed prior to the experiment termination.

*(Errors are defined as mistakes in carrying out the planned procedures. Unsuccessful sample preparation based on the unique nature of the samples or sample response to routine preparation methods is not considered an error. Investigators are encouraged to provide methods from literature as a basis for preparation of new samples in order to minimize potential sample preparation problems.)

6. MIC Facility Seed Grant Program

This grant program is intended to encourage faculty researchers at Texas A&M University to try something new using instruments and staff expertise in the MIC. The goal of the program is to help researchers show proof-of-concept and generate data that strengthens grant proposals, resubmissions, and manuscripts for peer review. Successful proposals will identify a new research idea that requires MIC equipment and staff expertise.

Eligibility

The program is open to all PI-eligible researchers in the TAMU System. Applicants do not need to be current users of the MIC. New users of the MIC and junior investigators are particularly encouraged to apply. Past seed grant awardees may submit additional proposals for new and distinct research projects.

Award Information

The seed grant will consist of up to 10 hours of MIC staff time to contribute to the research project, with a maximum value of \$600 based on \$60/hour tech rate. Instrument time is *not* included in the award. Depending on the instrument(s) used, rates vary between \$25-60/hour. Instrument fees can be found on the MIC website.

Application Process

Applications can be submitted electronically via email to Ashlyn Montgomery, amontgomery@tamu.edu. Please send an email with the subject line "MIC Seed Grant Application".

You will need to provide the following information:

1. Project title
2. PI name, department, and contact information
3. Student name and contact information, if applicable
4. Brief description of the research problem and the proposed methods
5. Type of sample, preparation needed, and expected results of imaging
6. Expected outcome of the grant; specify potential for funding or publication based on the results of this initial work, if applicable
7. Anticipated use of MIC to continue this work following the grant period
8. Supporting literature

Review Criteria

Proposals will be reviewed by MIC staff and awards will be made by the MIC director. Review criteria include project merit, clarity of the proposed work, and the facility's capacity to help meet the project's goals and objectives. New users of the MIC and junior investigators are encouraged to apply and may be given priority.

7. Export Controls

Texas A&M and the MIC also have a commitment to comply with all applicable export controls, as established by federal regulations, in its policy on export controls (see The Texas A&M University System Policy 15.02 Export Controls).

8. Confidentiality

Confidentiality is required for all MIC users who are members of the TAMU research community. External users of the facility are extended similar confidentiality treatment. Confidential disclosure/nondisclosure agreements are executed for external users upon request through the Contracts Administration (contracts.tamu.edu). The MIC will provide assistance in establishing such agreements.

(<https://financeits.tamu.edu/resources/protecting-confidential-information/>)

9. MIC Acknowledgment Policy

To best acknowledge the MIC in publications and presentations that have utilized the MIC facilities the following information should be cited where they are relevant:

- Type of system used, objective used, wavelengths of excitation and emission, camera, software, and any details of image processing or analysis procedures. These technical details can be found on their respective website pages.

Acknowledgement of the MIC in publications is appreciated and helps to show our usefulness to future funding sources. Acknowledgment of the efforts, contributions, and instrument usage of the MIC can be worded as follows: *“Use of the Texas A&M Microscopy and Imaging Center is acknowledged.”*

The FEI Quanta FE-SEM must have special acknowledgment per NSF guidelines as follows: *“The FE-SEM acquisition was supported in part by the National Science Foundation under Grant No. DBI-0116835.”*

10. MIC Floor Map

Microscopy and Imaging Center Interdisciplinary Life Sciences Building

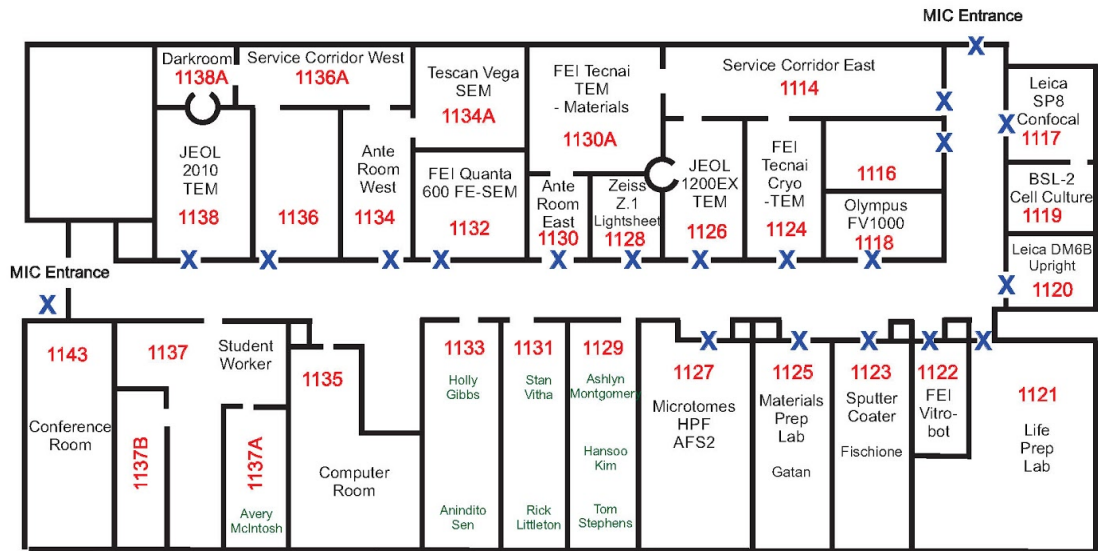

X Keycard Access Points